



**ELOTECH**  
INDUSTRIELELEKTRONIK

## R4010

**Extension module with 4 or 8 zones for the R4000 for mounting on the TS35 top-hat rail**

(Zones 9 – 16 on the R4000 display)



Mounting depth: 135mm  
Size: 90mm x 106mm

### Operating instructions

ELOTECH Industrieelektronik GmbH  
Verbindungsstrasse 27  
D - 40723 HILDEN  
TEL: +49 2103 / 255 97 0  
www.elotech.de

FAX: +49 2103 / 255 97 29  
E-Mail: info@elotech.de

# Content

- Content..... 2**
- 1 Installation and connection aid..... 3**
- 2 Type key ..... 4**
- 3 Images of the connection..... 5**
  - 3.1 Connection: Power supply / E-Bus .....5
  - 3.2 Address assignment: R4010.....6
  - 3.3 Connection: Sensor inputs .....7
  - 3.4 Connection: Logic outputs .....7
  - 3.5 Connection: Relay outputs .....8
  - 3.6 Connection: Continuous output (optional) .....8
- 4 Error messages..... 9**
- 5 Technical data ..... 10**

# 1 Installation and connection aid

It must be ensured that the devices described here are only used as intended. They are intended for top-hat rail mounting.

The device must be installed in such a way that it is protected from impermissible moisture and heavy soiling.

The approved ambient temperature range must not be exceeded.

The electrical connections must be made by a specialist in accordance with local regulations. Only sensors corresponding to the pre-programmed range may be connected. If thermocouples are connected, a compensating cable must be laid up to the controller terminal. Sensor cables and signal cables (e.g. logic output cables) must be laid separately from control and mains voltage cables (power cables).

To comply with CE conformity, shielded transmitter and signal cables must be used. Transducers and logic outputs must not be connected to each other externally.

Physical separation between the device and inductive loads is recommended.

Contactors coils must be suppressed by parallel-connected, adapted RC combinations. Control circuits (e.g. for contactors) should not be connected directly to the mains connection terminals of the device.

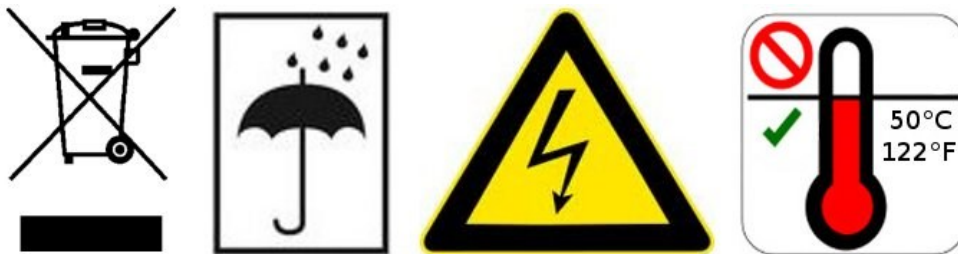

This description has been prepared with the greatest possible care. However, the information contained herein does not constitute a guarantee of product properties. The manufacturer accepts no liability for errors. The manufacturer reserves the right to make changes at any time in the interests of technical progress. All rights reserved.

Electrical waste and electronic components are subject to hazardous waste treatment and may only be disposed of by authorized specialist companies.

## 2 Type key

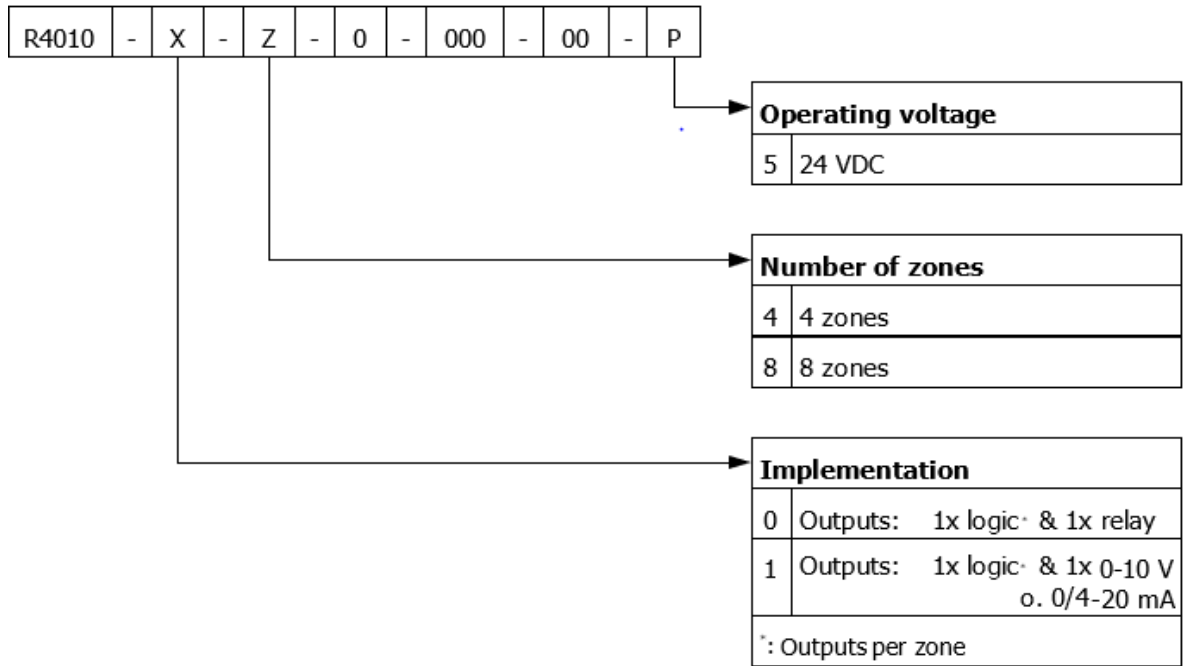

### 3 Images of the connection

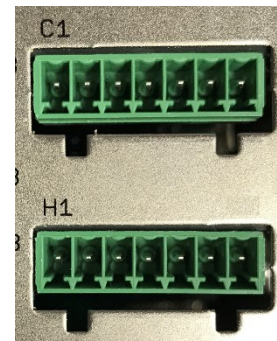

Continuous option

Electrical grounding

The earth connection (6.3 mm flat plug) must be connected to an earth bar as short as possible (<20 cm) with a thick cable (>=4qmm)!

#### 3.1 Connection: Power supply / E-Bus

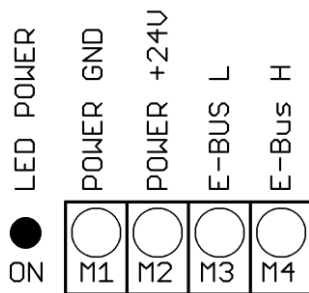

The LED lights up when the supply voltage is applied.

This expansion module is connected with the R4000 controller via the E-bus.

The "E-bus L" and "E-bus H" cables must be connected to the corresponding terminals of the R4000. The connection of the E-bus to the controller must be implemented as a shielded cable. The shield must be connected to earth (housing) on one side of the R4010.

### 3.2 Address assignment: R4010

The extension module can be set to 4 different addresses. Address 2 must be set for communication with the R4000 controller.

A terminating resistor is not required.

The addresses of the individual modules are set by the position of the DIP switches on the right-hand side of the device.

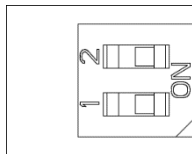

Address	DIP-switch 1	DIP-switch 2	Control zones
1	OFF	OFF	01-08
2	ON	OFF	9-16
3	OFF	ON	17-24
4	ON	ON	15-32

Please also note the correct setting of the total number of zones in the About menu of the R4000 controller.



For an extension module with 4 zones, the zone extension must be set to 12.

See detail A

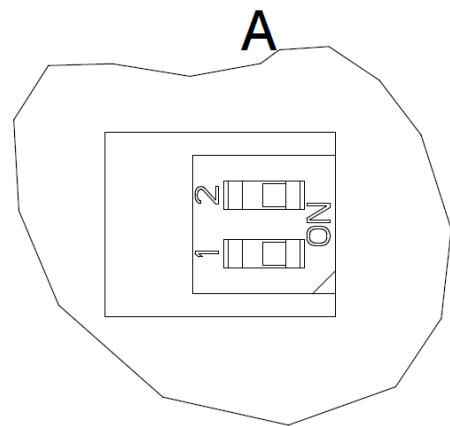
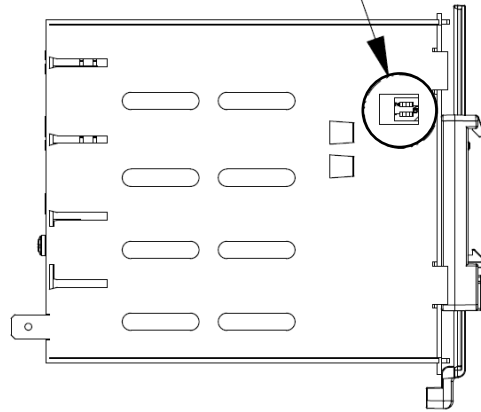

### 3.3 Connection: Sensor inputs

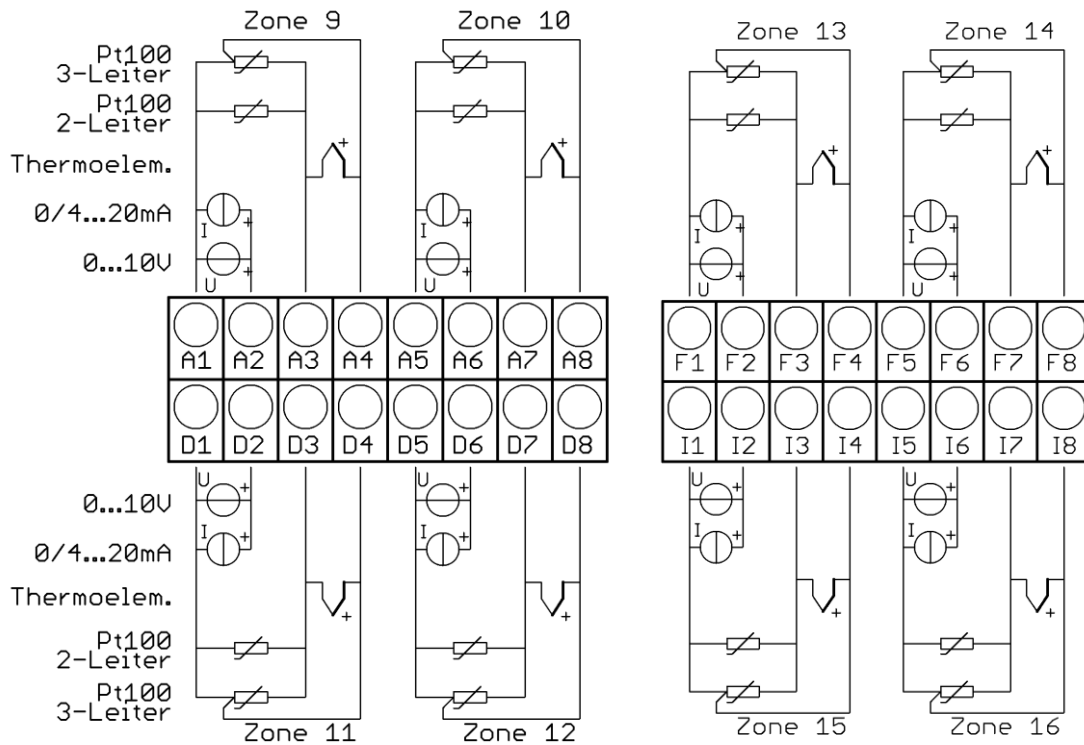

Sensors and logic outputs must not be connected to each other externally!

PT100/Ni120: Depending on the connection type (2-wire/3-wire), the probe/sensor parameter must be selected accordingly.

### 3.4 Connection: Logic outputs

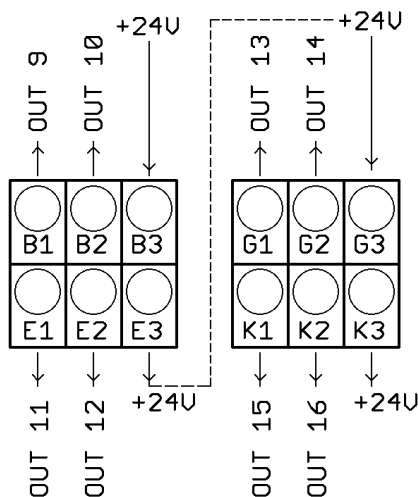

The supply voltage for the logic outputs must be wired externally: +24V must be applied to terminals B3 and G3.

B3 is connected internally to E3 and G3 to K3.

Terminals E3 and K3 can thus be used to bridge the +24V.

The control voltage 24V is output at the outputs Out x. The outputs Out X thus control the SSRs. The reference potential is the ground of the supply voltage.

### 3.5 Connection: Relay outputs

If the controller is equipped with continuous outputs, the relay outputs are omitted.

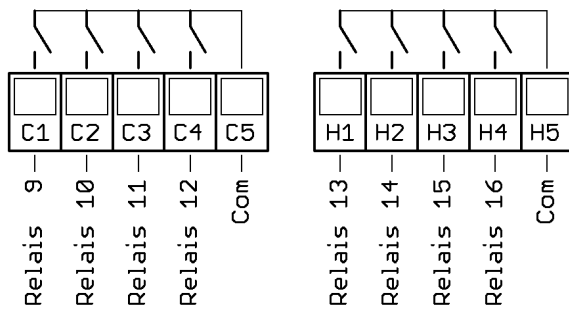

### 3.6 Connection: Continuous output (optional)

If the controller is equipped with relay outputs, the continuous outputs are omitted.

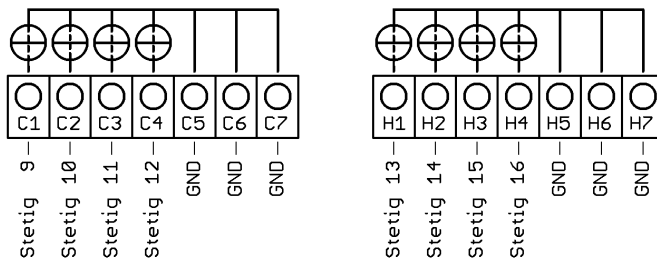

The GND terminals C5 - C7 and H5 - H7 are bridged. The output switches automatically to current or voltage, depending on the connected load.

## 4 Error messages

<b>Display</b>	<b>Meaning</b>	<b>Possible sources of error</b>
LED POWER does not light up	The 24V supply voltage is not present.	Check the power supply unit. Is the voltage reversed?
Module is not recognized by the R4000	Communication via the E-Bus is disturbed.	Check that the E-Bus cables are connected, and that the polarity is not reversed. Is the extension module in the R4000 enabled? See Main menu / System / About / → Parameter: Zone extension

## 5 Technical data

Input Pt100 (DIN)	2- or 3-wire circuit can be connected. Sensor break and short-circuit monitoring are built in. Sensor current: < 1 mA Accuracy: < 0,2 %    Linearity error: < 0,2 % Ambient temperature influence: < 0,01 % / K	
Input thermal element	Sensor break protection and internal cold junction are built in. Reverse polarity protection is provided.  Accuracy: < 0,25 %    Linearity error: < 0,2 % Cold junction error: 0,5K Ambient temperature influence: < 0,01 % / K	
Input voltage 0...10V	Internal resistance > 100 k-Ohm Accuracy: < 0,25 %    Linearity error: < 0,2 % Ambient temperature influence: < 0,01 % / K	
Input current 0...20mA	Internal resistance: < 100 Ohm Accuracy: < 0,25 %    Linearity error: < 0,2 % Ambient temperature influence: < 0,01 % / K  ! The input has a high impedance, when the controller is without operating voltage.	
Logic output	Voltage, bistable, 0/24 V DC, max. 500 mA, short-circuit proof	
Relay output	Relay normally open NO; max. 250V AC, max. 2A, resistive load	
Continuous output	0...20 mA load resistance max. 300 Ohm; 0...10 V min. 5kOhm. Automatic switching, depending on the connected load resistance.	
Operating output	24 V DC, +/-25 %, ca. 3W + Power of the logic outputs	
Housing for mounting on TS35 top-hat rail	Size of the housing: Housing material: Type of protection:	90x106mm, Installation depth: 135 mm Sheet steel and polyamide UL 94-V2 IP 20 (DIN 40050)
Electrical connections	Plug-in terminal strips, Protection class IP 20 (DIN 40050), Insulation group: C Cross sections: Terminal groups: A, B, D, E, F, G, I, K, M, + C, H (continuous) = 1,5 mm <sup>2</sup> (for end sleeves with plastic collar 0,75mm <sup>2</sup> ) Terminal groups: C, H (Relays)= 2,5mm <sup>2</sup>	
Weight	approx. 600g, depending on version	
Permitted areas for application	Working temperature: Storage temperature: Climate application class:	0...50°C / 32...122°F -30...70°C / -22...158°F KWF DIN 40040; corresponds to 75 % relative humidity on an annual average, no condensation
CE – Label (EMC)	EN 61326-1:2013 / EN 61000-3-2:2006+A1:2009+A2:2009 EN 61000-3-3:1995+A1:2001+A2:2005 Electrical safety: EN 61010-1	

Technical changes reserved